

City of Sugar Hill
Planning Staff Report
AX 22-001

DATE: August 31, 2022; *Updated 9/9/2022*
TO: Mayor and City Council
FROM: Planning Director
SUBJECT: Annexation AX 22-001
5768, 5778, & 5788 Suwanee Dam Road

ISSUE: Annexation of this 16.5 acres owned by the Sells and Zimmer families was initiated by an application from Andy Perry with ONBR, LLC, dated June 24, 2022. Applicant is requesting medium density single-family residential (RS-100) with planned residential development (PRD) overlay zoning for 41 single-family detached homes.

RECOMMENDED ACTION

Approval of annexation and rezoning as requested to RS-100 / PRD with the following conditions:

1. All streets, alleys, sidewalks (except those required within the Suwanee Dam Road public right-of-way), storm water facilities and other common areas or facilities shall be privately owned and maintained.
2. All property will be subject to and maintained by a mandatory Homeowner's Association (HOA). Prior to receiving a certificate of occupancy for 49% of the homes in the subdivision, developer shall deposit \$20,000 into a capital reserve account for future maintenance and repair of all streets, alleys, sidewalks, storm water facilities and common areas.
3. Site plan and buildings shall be constructed to substantially resemble the attached *Exhibits 1-6*. The builder(s) shall be required to use at least three distinct house plans and elevations subject to approval by the City Manager. Variations in materials, color and architectural details shall be required such that no elevation is used on more than 40% of the total homes in the project.
4. Prior to final plat approval, a dedicated left turn lane shall be provided at the project entrance on Suwanee Dam Road. Project access improvements shall be subject to Gwinnett County and City of Sugar Hill approval.
5. Developer shall coordinate with the City of Sugar Hill and provide an easement for future construction of the Sugar Hill Greenway.
6. Builder shall provide a minimum of three gas appliances in each home prior to certificate of occupancy.
7. *Covenants shall stipulate that no more than 10% off the total number of dwelling units are allowed to be leased at any one time.*

PLANNING COMMISSION PUBLIC HEARING AND RECOMMENDATION:

The Planning Commission held a scheduled public hearing on August 15, 2022. Andrew Perry, developer and builder spoke in support of this request and indicated he’s had dialogue with Wild Timber and Kendrix Ridge on sewer access and availability. He is in the process of providing additional elevations to satisfy the staff condition of zoning item #3. Amber Chambers spoke in opposition to this request and stated that she was not so much in opposition because she is glad to see single family detached homes instead of townhomes. She also stated that she thought this is because of the neighboring subdivisions, that not everybody gets the same consideration. She also stated that she did not see anything in the interactive map pertaining to these homes being fee simple, for lease or anything about a price to know if this is affordable housing. She also stated that she thinks that is a thing a lot of people in the community are concerned about and that we don’t need a lot of really expensive homes and people are looking for work force housing. She also stated that there should be a condition requiring limitation on rental homes. Andrew Perry indicated these would be fee simple homes with starting prices exceeding \$600,000 range but would be driven by the market and would be more likely in the high \$700,000 range. Andrew Schulz questioned what PRD meant. Kim Landers indicated in simple terms, would be site plan specific and recommendation was RS100. [Staff recommendation is RS-100/PRD] The public hearing was closed.

Planning Commission Member Phil Olsen made a motion to approve the annexation request with a RS-100 zoning as recommended by staff with conditions. Commission Member Jason Jones made the second. Motion was approved 3 for, 1 against (Commission Member Rosemary Walsh against).

DISCUSSION

- The proposed annexation meets state requirements under the 100% method and does not create an unincorporated island. Gwinnett County Board of Commissioners and Gwinnett County Public School Board were notified and have not submitted objection to the proposed development.
- Future land use designation for the property in the county is Chattahoochee River Area and is surrounded by Established Neighborhood and Greenspace in the City of Sugar Hill. Planning staff recommends a land use character designation of Established Neighborhood.
- Proposed residential subdivision has an average lot size of 10,740 square feet and is consistent with the existing character of surrounding development.

BACKGROUND

Applicant / Owner:	Andy Perry / ONBR, LLC
Existing Zoning:	Single-family residential (R100) in Gwinnett County
Request:	Annex and rezone to RS-100/PRD with front and side setback variances.
Purpose:	Single-family detached residential subdivision for 41 homes.
Property Size:	± 16.51 Acres
Location:	5768, 5778, & 5788 Suwanee Dam Road, Tax Parcels # 7-340-036, 7-340-184, & 7-340-040
Public Notice:	Public notice signs posted on 7/27/22. Legal advertisements were/to be published in Gwinnett Daily Post on 7/27/22, 8/3/22, 8/10/22, 8/24/22, 8/31/22, and 9/7/22.
Public Comment	Public comments during 8/15/2022 public hearing summarized above. Brighton Park resident, Terese Huber submitted comments by email opposing the proposed development.

FINDINGS OF FACT

Surrounding Land Use and Zoning

Direction	Existing Land Use	Existing Zoning
North	Greenspace, single-family residences in Kendrix Ridge subdivision	RS-100
South	Single-family residence	R100
East	Single-family residences in Suwanee Reserve subdivision	R75
West	Single-family residences in Wild Timber subdivision	RS-150

*City of Sugar Hill: Medium Density Single Family Residential (RS-100), Low Density Single Family Residential (RS-150)
Gwinnett County: Single-Family Residence (R100 & R75)*

ZONING ANALYSIS

1. Will the rezoning requested permit a use that is suitable in view of the use and development of adjacent and nearby property?

Yes. The requested zoning is similar to and suitable with the surrounding developed properties.

2. Will the rezoning requested adversely affect the existing use or usability of adjacent or nearby properties?

No. The proposed zoning does not impose any additional use restrictions or any unusual or undue hardship on adjoining or nearby properties.

3. Does the property for which the rezoning is requested have a reasonable economic use as currently zoned?

Yes.

4. Will the rezoning requested create an overcrowding condition with respect to the existing streets, transportation facilities, or schools?

No. Additional vehicle trips and student enrollments are anticipated however, the effects of this development will be mitigated through zoning conditions, development requirements and planning. Suwanee Dam Road is a popular north-south minor arterial road with an average daily trip volume of over 23,000 ADT. The additional trips generated by the proposed subdivision will not substantially affect nearby intersection performance on Suwanee Dam Road.

It should be noted that due to current student enrollment, an addition is planned for North Gwinnett High School (NGHS). It is scheduled to be complete by the 2023-2024 school year. When these homes might be built, there will be excess capacity at NGHS. At this time, there is no indication that student capacity in the other North Gwinnett cluster schools is a concern.

5. Does the rezoning requested conform to the Sugar Hill Land Use Plan?

Yes. The prevailing character area in the vicinity of the subject property is Established Neighborhoods. The requested RS-100 zoning provides for an appropriate land use and recommended development patterns for that character area.

6. Are there other existing or changing conditions affecting the use and development of the property which would give support to an approval or disapproval of the rezoning request?

No.

LETTER OF INTENT
REQUEST FOR ANNEXATION & REZONING
SUGAR HILL, GEORGIA

Re: 16.51 acres located at 5778 and 5788 Suwanee Dame Road, Sugar Hill, GA, 30518

As authorized by the property owners, the Sellers and Zimmer families, Creekside Communities, LLC, respectfully submits this Letter of Intent to the City of Sugar Hill Planning & Development Department in support of an application for annexation from Gwinnett County to the City of Sugar Hill, and rezoning from R-100 to RS100-PRD zoning for the subject property.

The entire subject property consists of 16.51 acres and is located at 5788 and 5778 Suwanee Dam Road, Sugar Hill, GA 30518. This is a residential use area of unincorporated Gwinnett County.

The parcel is planned and intended to be developed as a small single-family home neighborhood consisting of 41 homes. For each home there will be a minimum of 4 parking spaces, or 164 spaces in total. However, there will be a mix of 2 and 3 car garage homes. The exteriors of the homes will be primarily brick, with accents and gables of cedar and hardi shake and siding. The elevations will be subject to review and approval by the City of Sugar Hill. There will be a minimum heated floor area of 2600 SF, but the majority of the homes will exceed this as referenced by the plans in this zoning package. The home prices will begin in the high \$600 thousands. The maximum height of any given home is 35 ft. All of the appropriate documents and forms have been included in the application packet to allow for comprehensive review and approval of the proposed annexation and rezoning. The proposed zoning will incorporate at least 3 gas appliances per home.

The requested zoning is RS100-PRD. The streets will be private with a minimum 44' utility/access easement centered on the roadway.

The adjacent properties are zoned R75, R100, RS100 and RS100-PRD which makes us believe this zoning proposal is consistent with the surrounding area.

As shown on the site plan submitted in support of this application, primary access to the development is proposed to be provided from Suwanee Dam Road.

We thank you for your consideration of this application.

AX-22-001 – Subject Properties

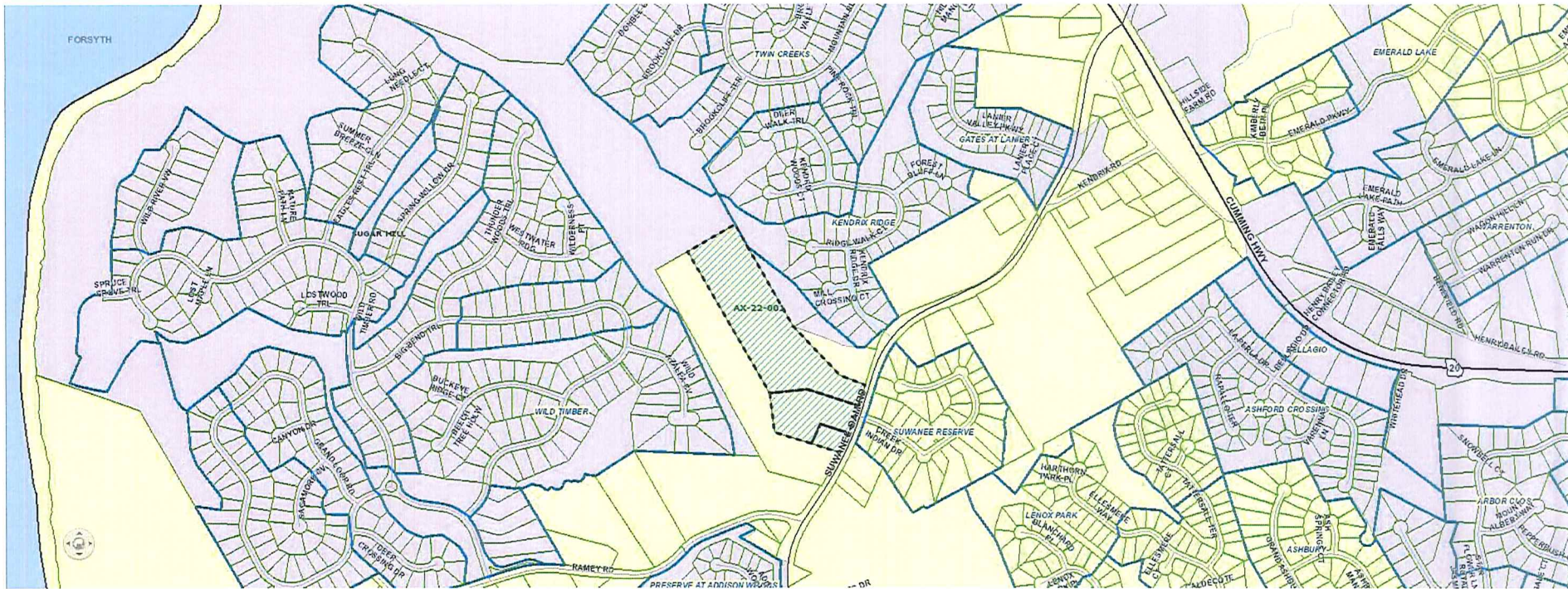

CC0208 LY3 Williamson



Copyright © American Gables Home Designs, Inc.

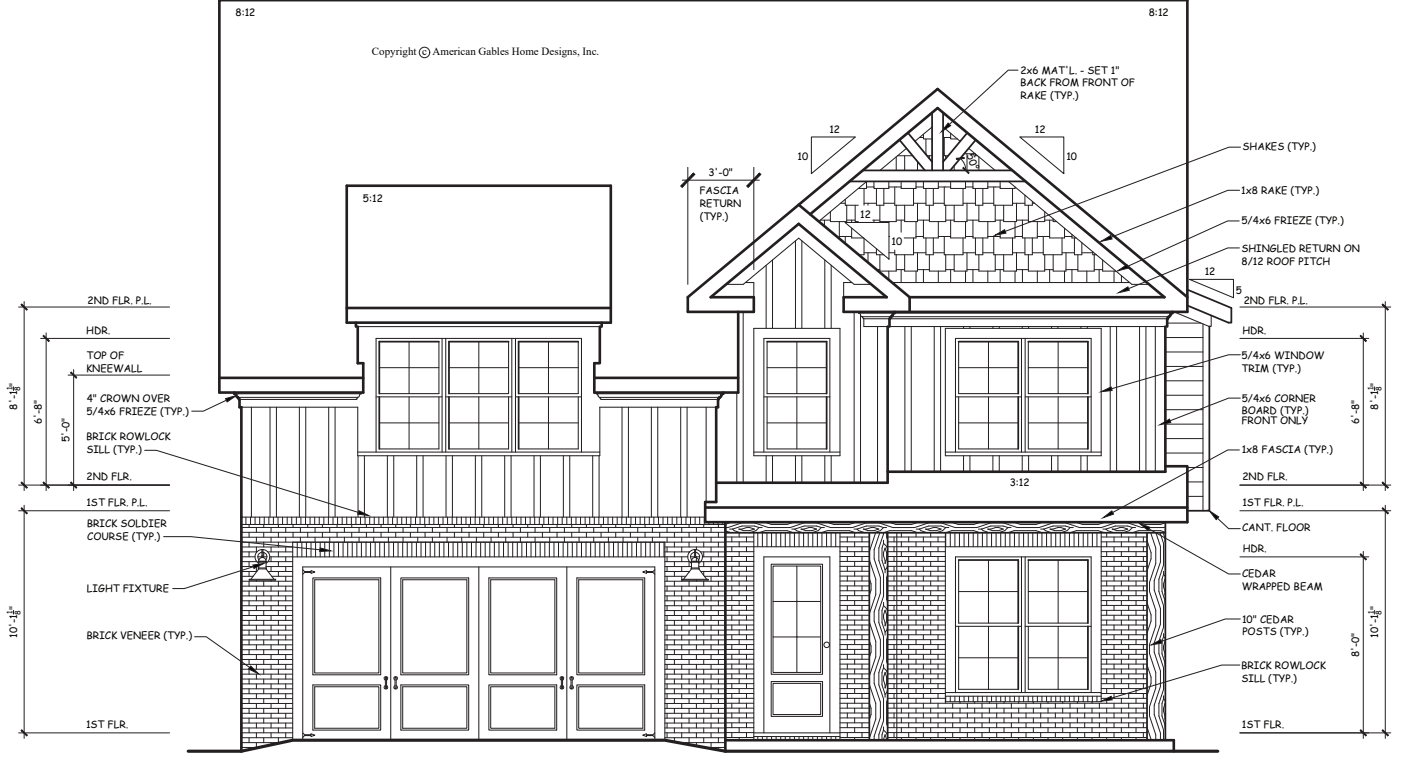

1 FRONT ELEVATION
A1.1 SCALE: 1/4" = 1'-0"

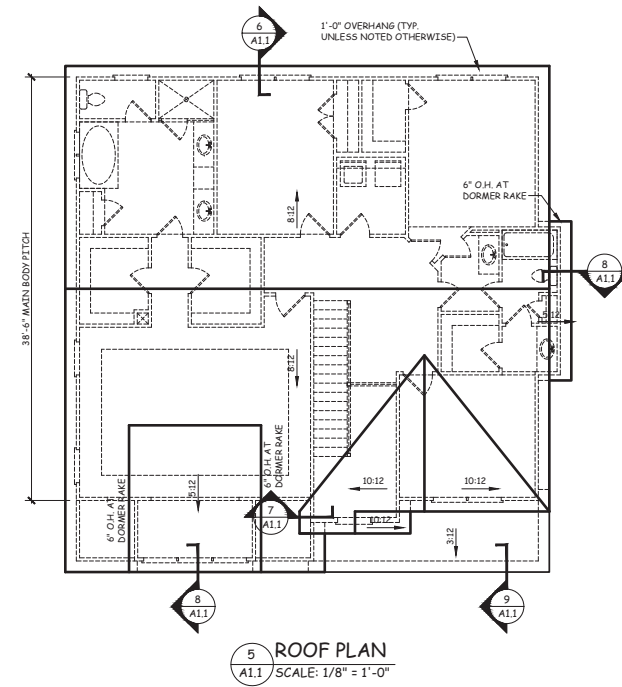

NOTE:
1. WHEN TWO ROOFS INTERSECT WITH DIFFERENT ROOF PITCHES, ADD BLOCKING TO STEEPER PITCH AS REQUIRED TO LINE UP FASCIAS AT A MINIMUM OF 1'-0" OVERHANG.
2. ELEVATIONS REFLECT A BASEMENT FOUNDATION IF ANOTHER FOUNDATION IS USED, BUILDER SHOULD DISREGARD FOUNDATION SHOWN.
3. PROVIDE ATTIC VENTILATION PER LOCAL CODES AND REQUIREMENTS.
4. FOUNDATION WALLS, RETAINING WALLS, BASEMENT WINDOWS AND DOORS ARE SUBJECT TO CHANGE DUE TO CHANGING SITE CONDITIONS.

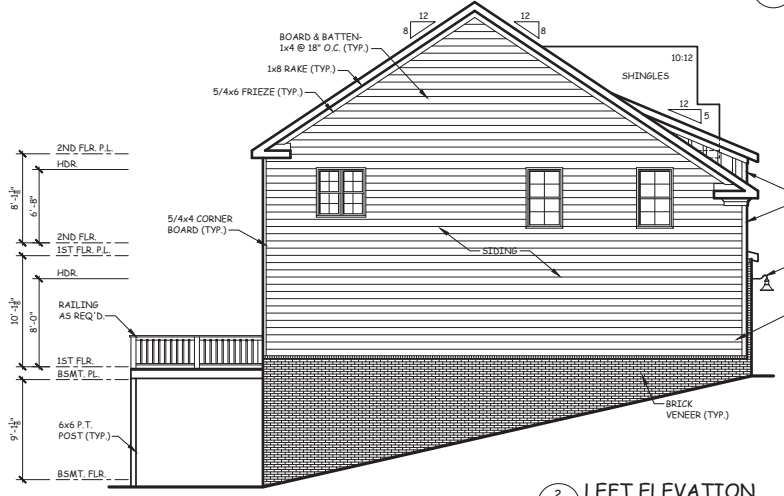

2 LEFT ELEVATION
A1.1 SCALE: 1/8" = 1'-0"

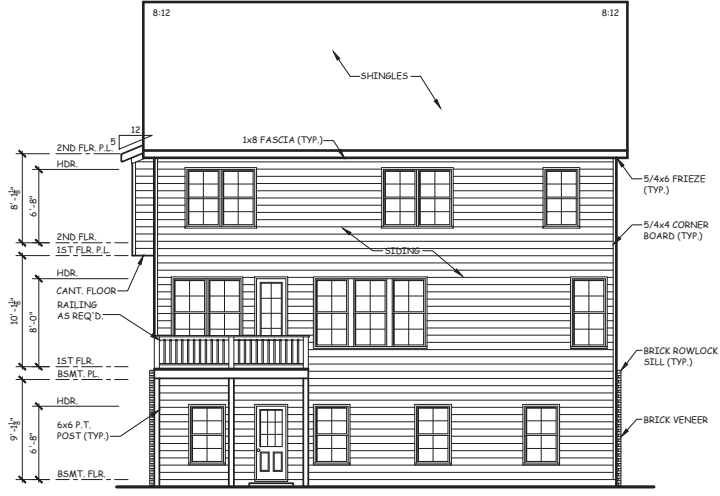

3 REAR ELEVATION
A1.1 SCALE: 1/8" = 1'-0"

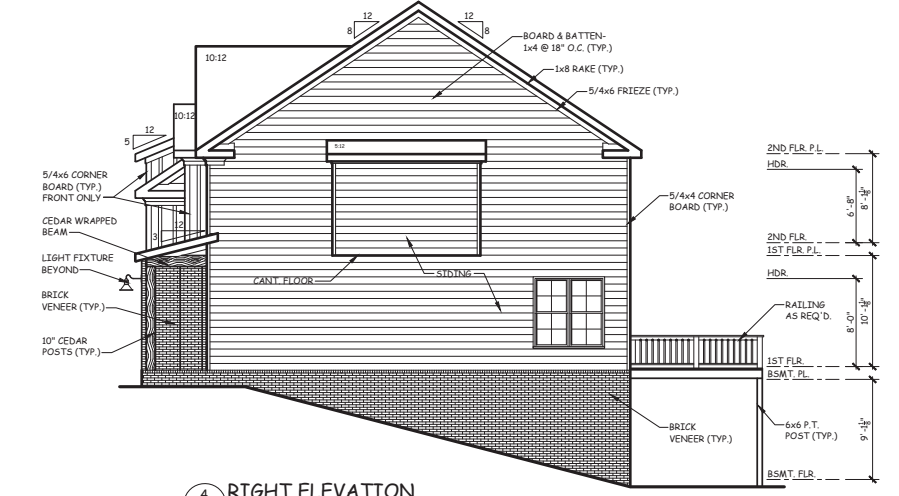

4 RIGHT ELEVATION
A1.1 SCALE: 1/8" = 1'-0"

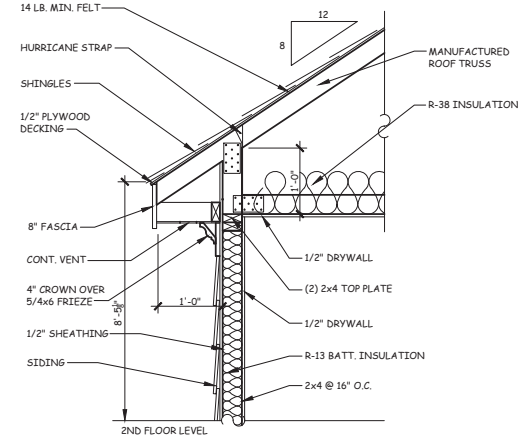

6 ROOF TRUSS DETAIL
A1.1 SCALE: 3/4" = 1'-0"

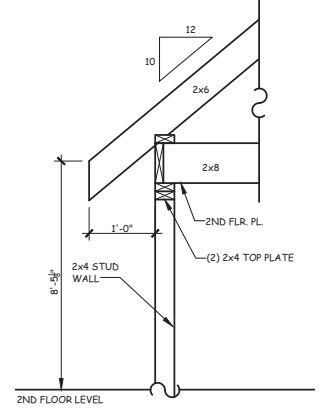

7 RAFTER FRAMING DETAIL
A1.1 SCALE: 3/4" = 1'-0"

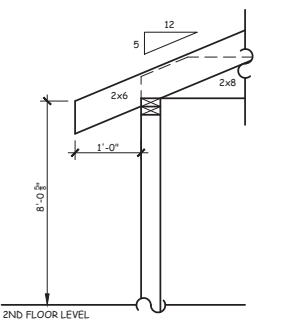

8 RAFTER FRAMING DETAIL
A1.1 SCALE: 3/4" = 1'-0"

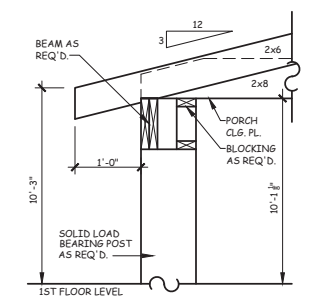

9 PORCH FRAMING DETAIL
A1.1 SCALE: 3/4" = 1'-0"

BUILDER
CREEKSIDE COMMUNITIES

WHITEHEAD
FRONT, SIDE & REAR ELEVATIONS /
ROOF PLAN & DETAILS

American Gables
HOME DESIGNS, INC.
3000 Johnson Ferry Road, Suite 206
Marietta, GA 30062 678-919-7717
www.AmericanGables.com

DRAWN BY: DCF
DATE: 07/06/22
REVISIONS:
SHEET
A1.1B
STANDARD

Copyright © American Gables Home Designs, Inc.

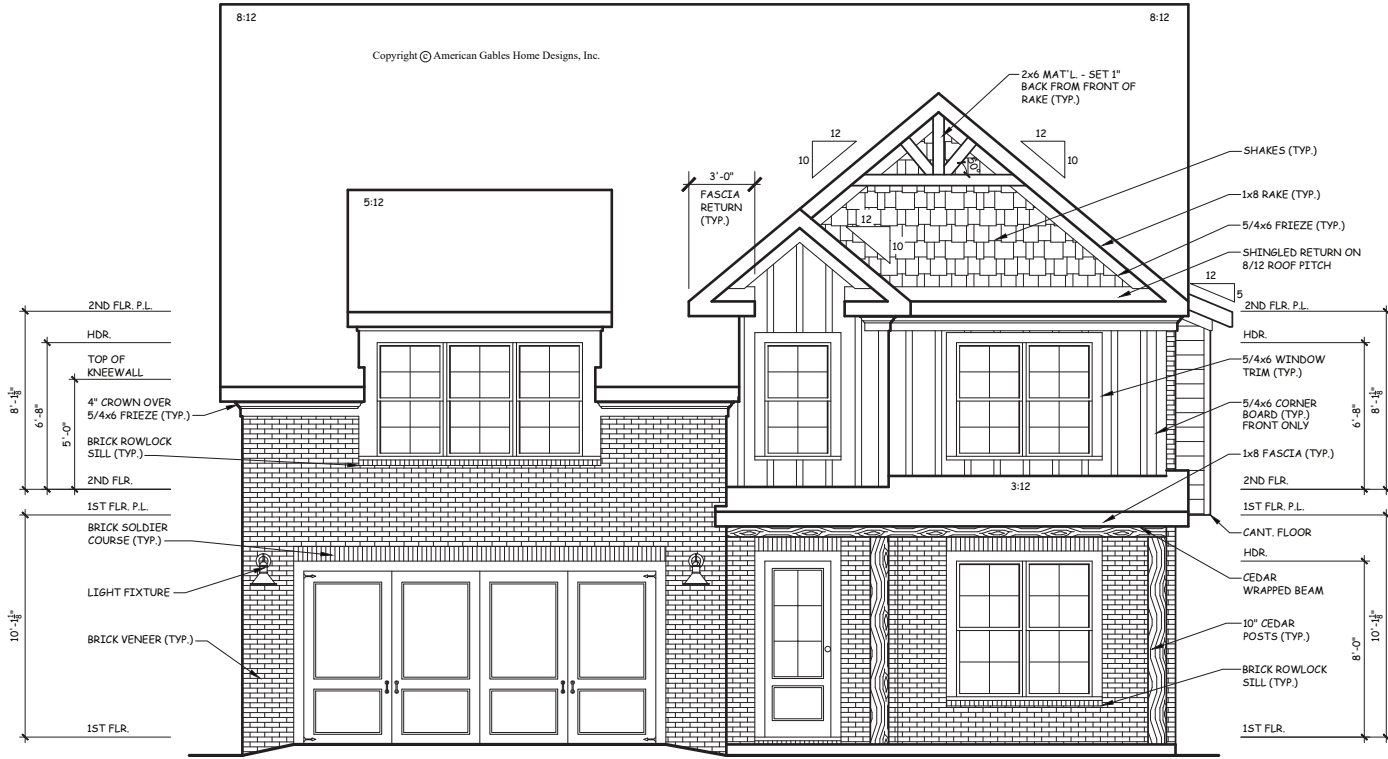

1 FRONT ELEVATION
A1.1 SCALE: 1/4" = 1'-0"

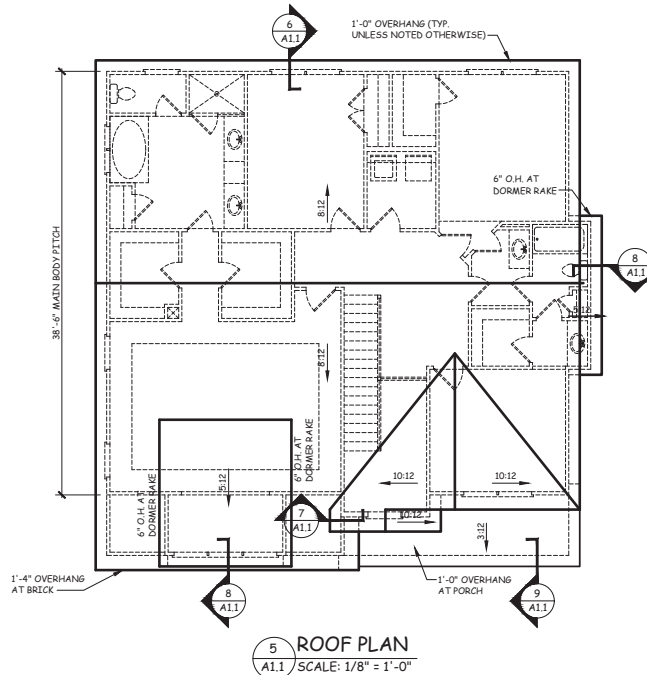

5 ROOF PLAN
A1.1 SCALE: 1/8" = 1'-0"

- NOTE:
1. WHEN TWO ROOFS INTERSECT WITH DIFFERENT ROOF PITCHES, ADD BLOCKING TO STEEPER PITCH AS REQUIRED TO LINE UP FASCIAS AT A MINIMUM OF 1'-0" OVERHANG.
 2. ELEVATIONS REFLECT A BASEMENT FOUNDATION IF ANOTHER FOUNDATION IS USED, BUILDER SHOULD DISREGARD FOUNDATION SHOWN.
 3. PROVIDE ATTIC VENTILATION PER LOCAL CODES AND REQUIREMENTS.
 4. FOUNDATION WALLS, RETAINING WALLS, BASEMENT WINDOWS AND DOORS ARE SUBJECT TO CHANGE DUE TO CHANGING SITE CONDITIONS.

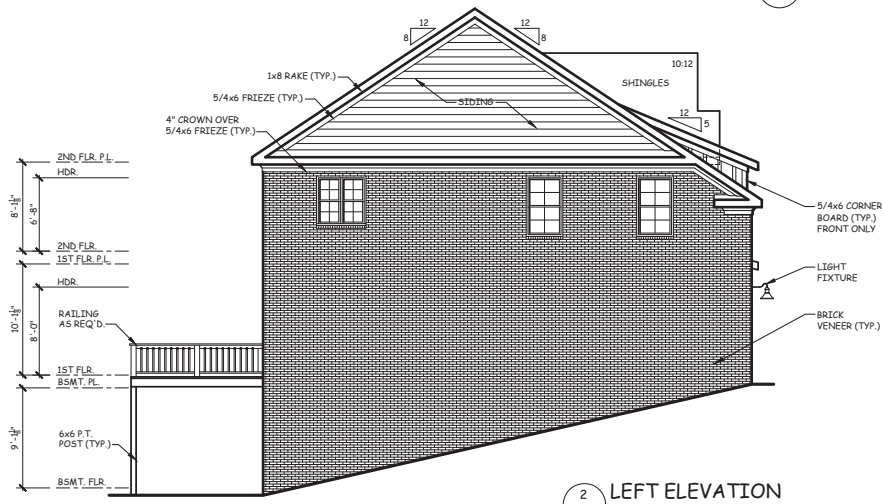

2 LEFT ELEVATION
A1.1 SCALE: 1/8" = 1'-0"

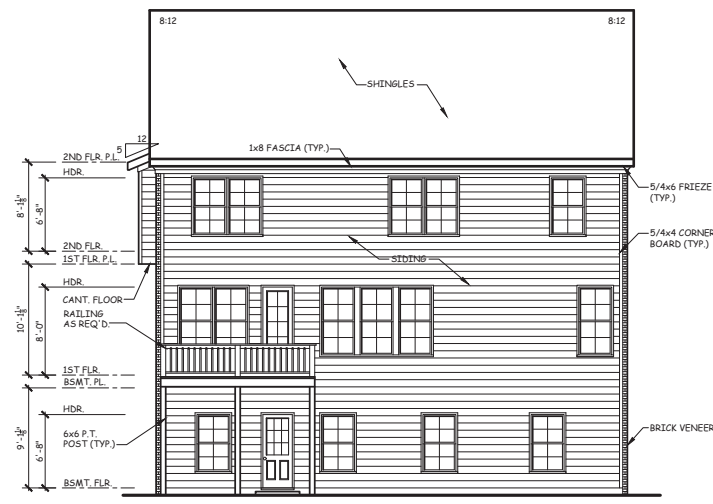

3 REAR ELEVATION
A1.1 SCALE: 1/8" = 1'-0"

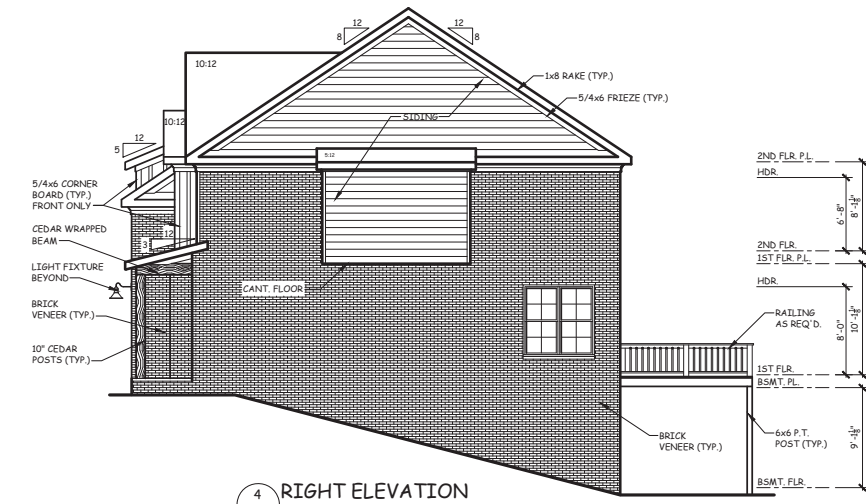

4 RIGHT ELEVATION
A1.1 SCALE: 1/8" = 1'-0"

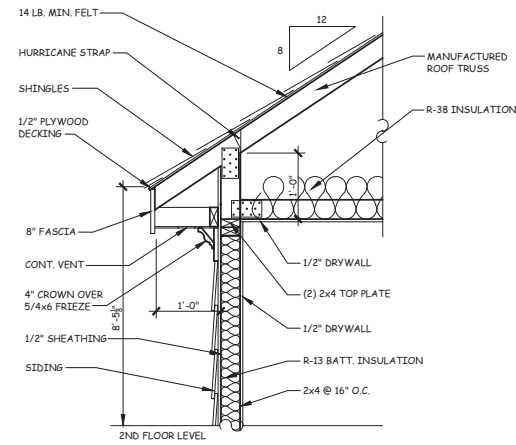

6 ROOF TRUSS DETAIL
A1.1 SCALE: 3/4" = 1'-0"

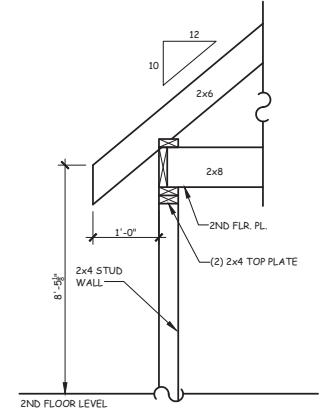

7 RAFTER FRAMING DETAIL
A1.1 SCALE: 3/4" = 1'-0"

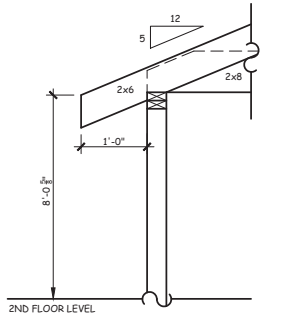

8 RAFTER FRAMING DETAIL
A1.1 SCALE: 3/4" = 1'-0"

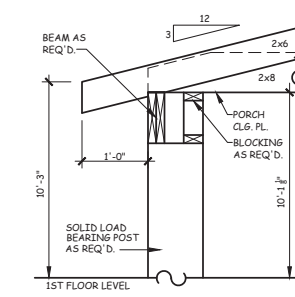

9 PORCH FRAMING DETAIL
A1.1 SCALE: 3/4" = 1'-0"

BUILDER
CREEKSIDE COMMUNITIES

WHITEHEAD
FRONT, SIDE & REAR ELEVATIONS /
ROOF PLAN & DETAILS

American Gables
HOME DESIGNS, INC.
3000 Johnson Ferry Road, Suite 206
Marietta, GA 30062 678-919-7717
www.AmericanGables.com

DRAWN BY: DCF
DATE: 07/06/22

NO.	REVISIONS

SHEET
A1.1B3B
STANDARD

Copyright © American Gables Home Designs, Inc.

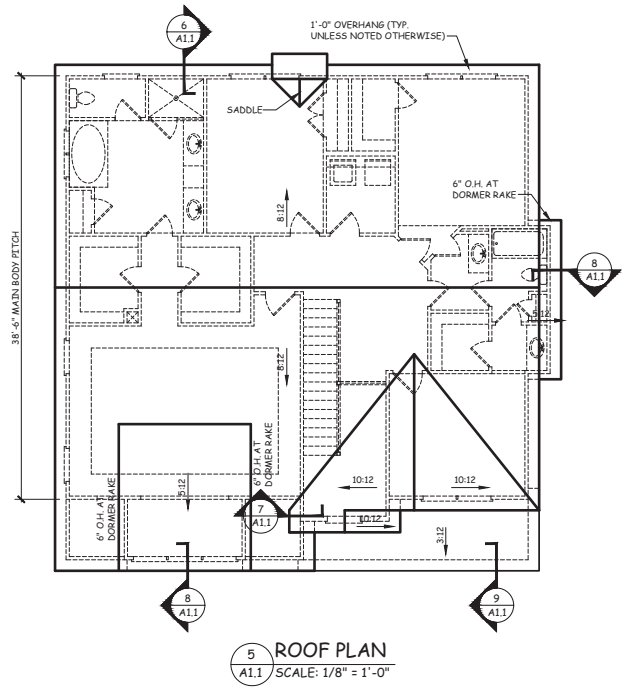
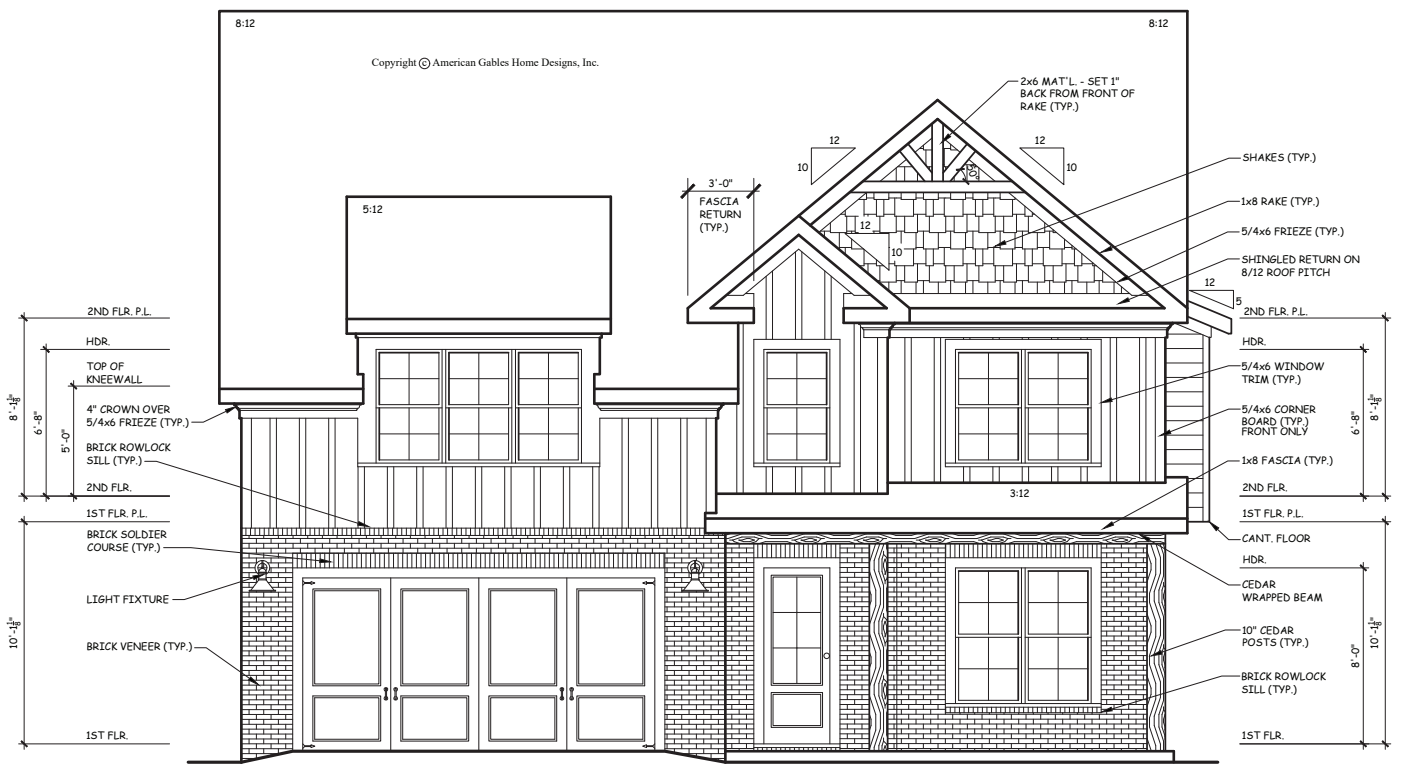

NOTE:
1. WHEN TWO ROOFS INTERSECT WITH DIFFERENT ROOF PITCHES, ADD BLOCKING TO STEEPER PITCH AS REQUIRED TO LINE UP FASCIAS AT A MINIMUM OF 1'-0" OVERHANG.
2. ELEVATIONS REFLECT A BASEMENT FOUNDATION IF ANOTHER FOUNDATION IS USED, BUILDER SHOULD DISREGARD FOUNDATION SHOWN.
3. PROVIDE ATTIC VENTILATION PER LOCAL CODES AND REQUIREMENTS.
4. FOUNDATION WALLS, RETAINING WALLS, BASEMENT WINDOWS AND DOORS ARE SUBJECT TO CHANGE DUE TO CHANGING SITE CONDITIONS.

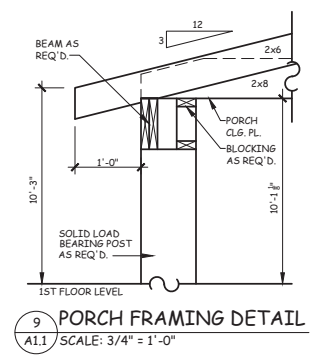
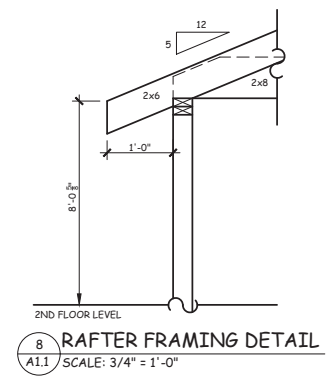
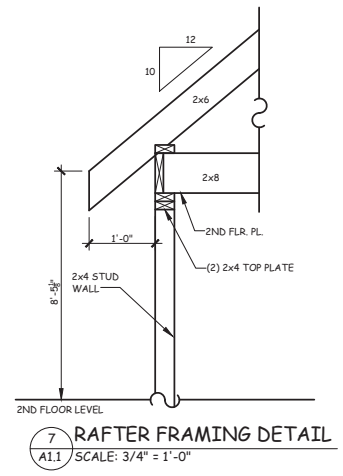
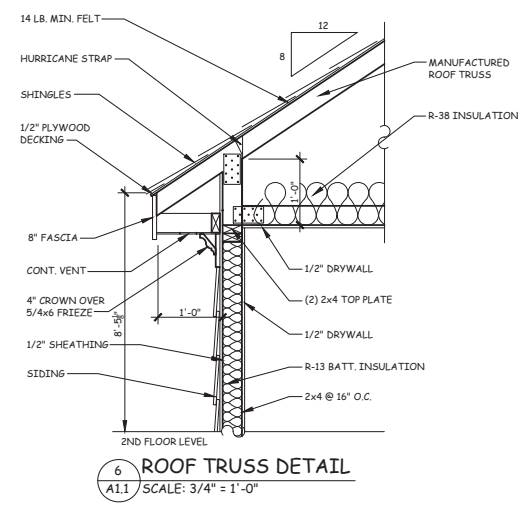
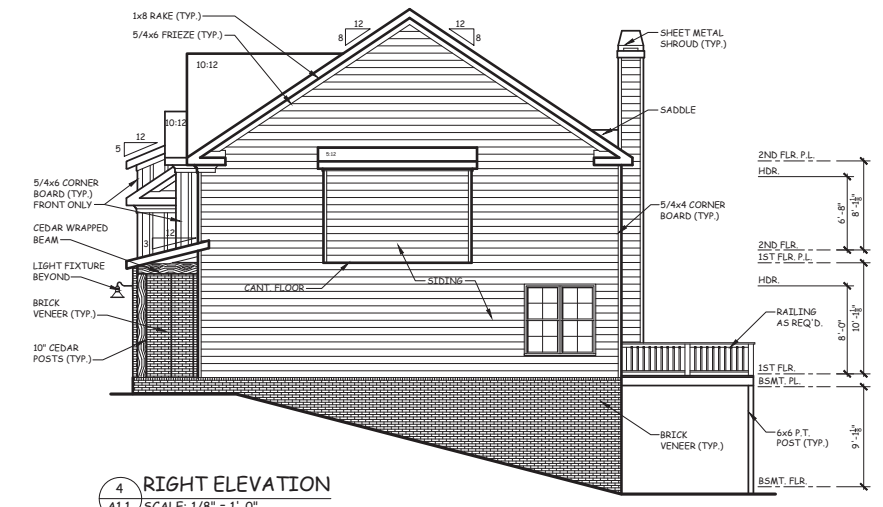
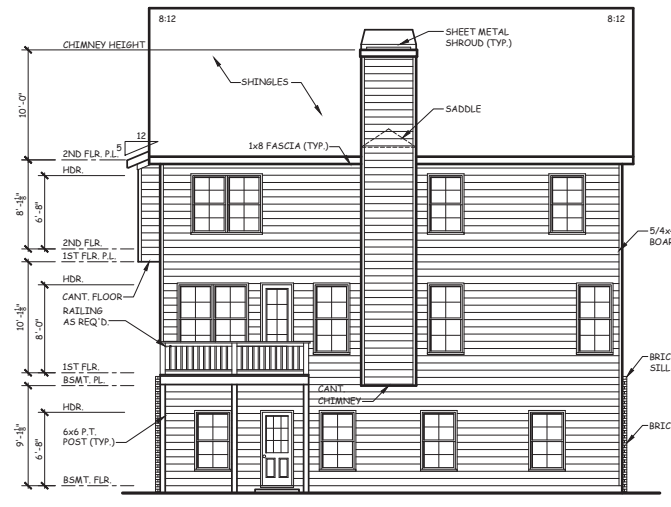
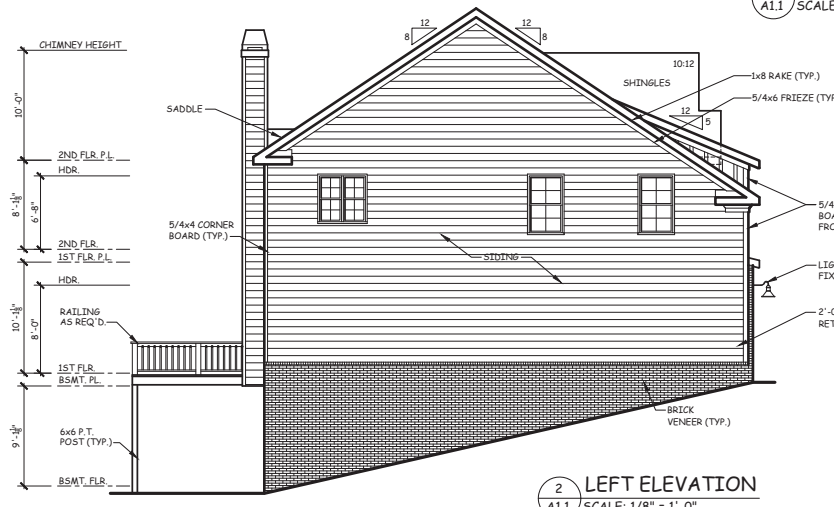

BUILDER
CREEKSIDE COMMUNITIES

WHITEHEAD
FRONT, SIDE & REAR ELEVATIONS /
ROOF PLAN & DETAILS

American Gables
HOME DESIGNS, INC.
3000 Johnson Ferry Road, Suite 206
Marietta, GA 30062 678-919-7717
www.AmericanGables.com

DRAWN BY: DCF
DATE: 07/06/22
REVISIONS:

SHEET
A1.1B
OPT. FAMILY RM.

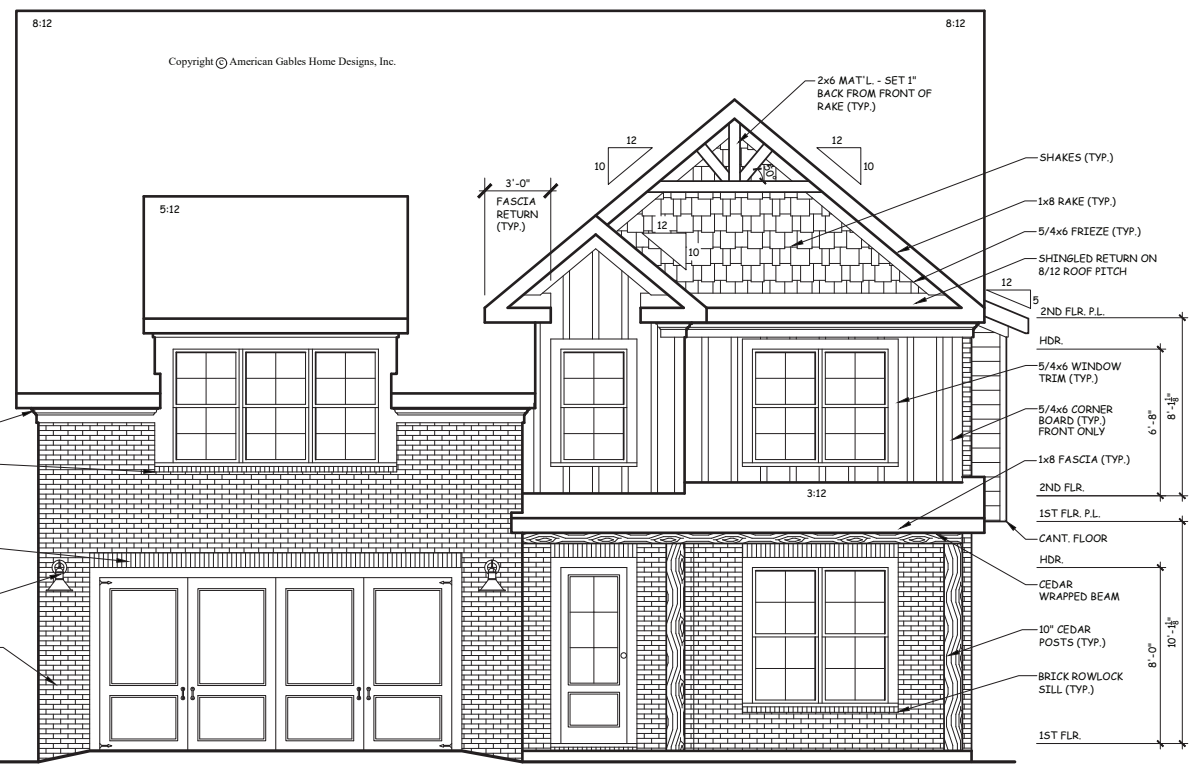

1 FRONT ELEVATION
A1.1 SCALE: 1/4" = 1'-0"

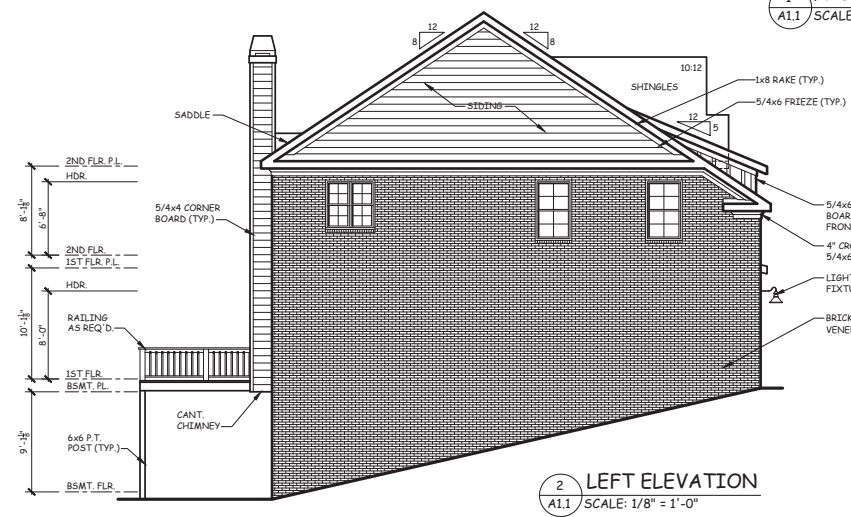

2 LEFT ELEVATION
A1.1 SCALE: 1/8" = 1'-0"

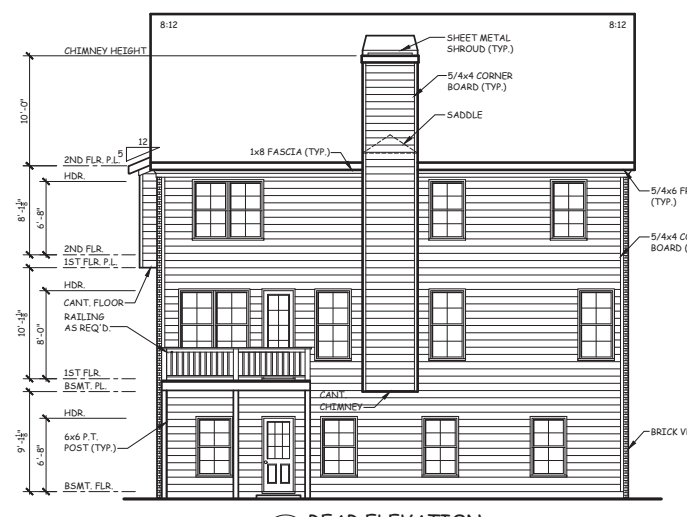

3 REAR ELEVATION
A1.1 SCALE: 1/8" = 1'-0"

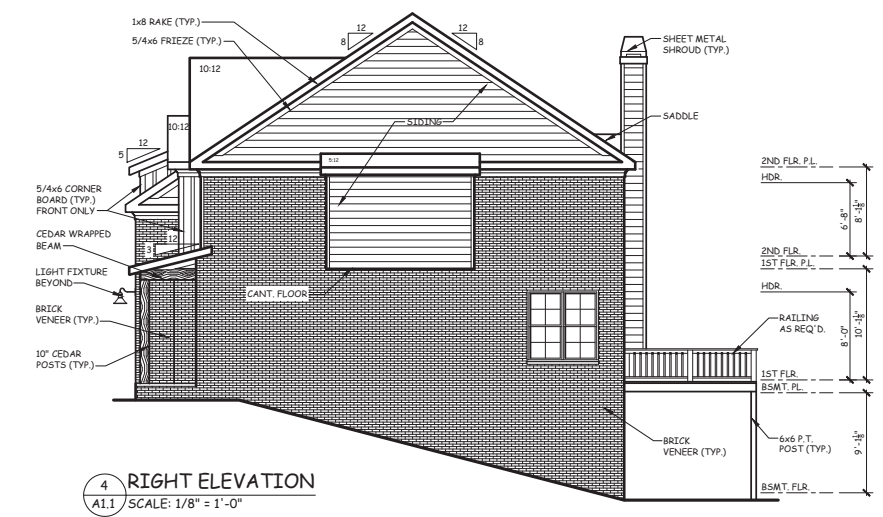

4 RIGHT ELEVATION
A1.1 SCALE: 1/8" = 1'-0"

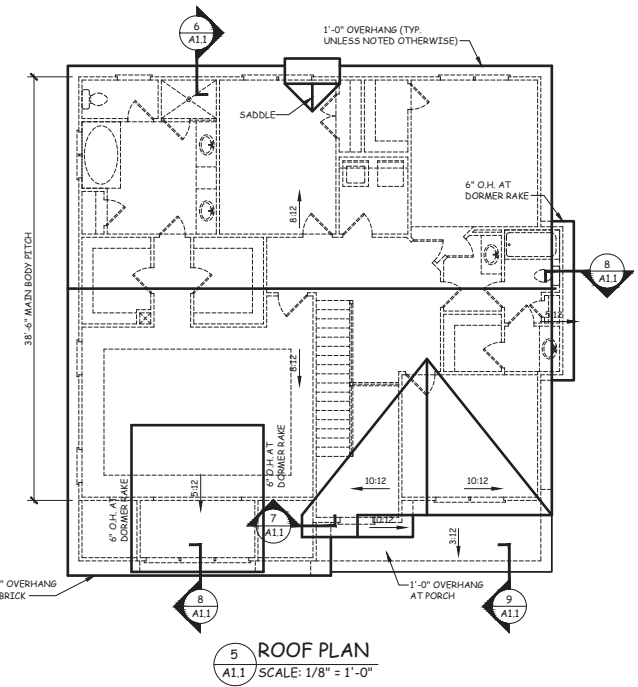

NOTE:

1. WHEN TWO ROOFS INTERSECT WITH DIFFERENT ROOF PITCHES, ADD BLOCKING TO STEEPER PITCH AS REQUIRED TO LINE UP FASCIAS AT A MINIMUM OF 1'-0" OVERHANG.
2. ELEVATIONS REFLECT A BASEMENT FOUNDATION IF ANOTHER FOUNDATION IS USED, BUILDER SHOULD DISREGARD FOUNDATION SHOWN.
3. PROVIDE ATTIC VENTILATION PER LOCAL CODES AND REQUIREMENTS.
4. FOUNDATION WALLS, RETAINING WALLS, BASEMENT WINDOWS AND DOORS ARE SUBJECT TO CHANGE DUE TO CHANGING SITE CONDITIONS.

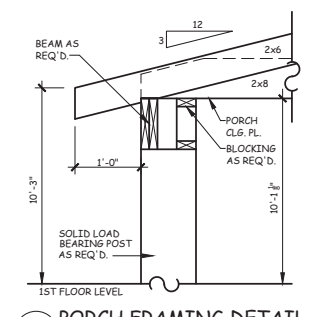
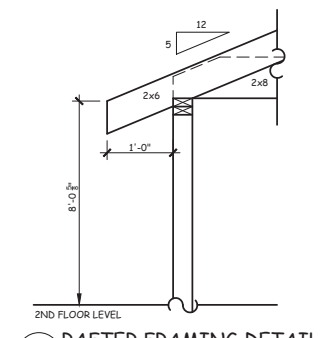
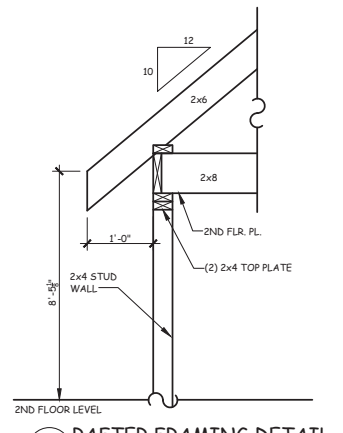
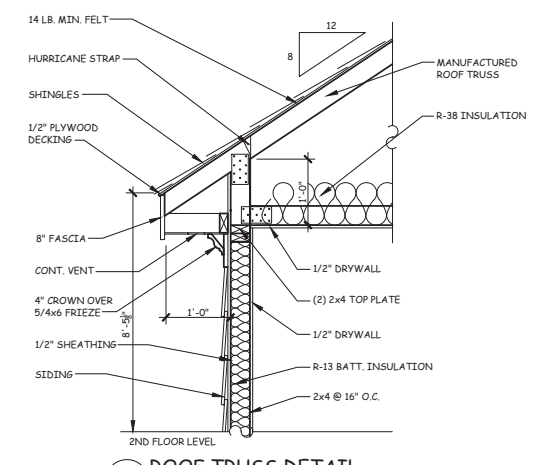

BUILDER

CREEKSIDE COMMUNITIES

WHITEHEAD

FRONT, SIDE & REAR ELEVATIONS / ROOF PLAN & DETAILS

American Gables HOME DESIGNS, INC.
 3000 Johnson Ferry Road, Suite 206
 Marietta, GA 30062 678-919-7717
 www.AmericanGables.com

DRAWN BY: DCF
 DATE: 07/06/22

NO.	REVISIONS

SHEET

A1.1B3B
 OPT. FAMILY RM.

LEGEND	
	STAKING
	CURB & GUTTER
	RETAINING WALL TYPES
	SIDEWALK
	HANDICAP RAMP
	RISE
	COORDINATE NUMBER
	HANDICAP PARKING SYMBOL

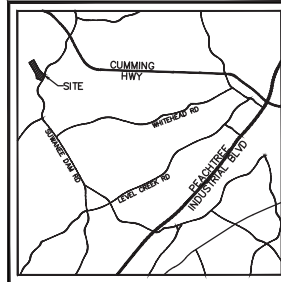

VICINITY MAP
N.T.S.

PRD - LOT SIZE REDUCTION CALCULATIONS	
TOTAL LOTS	41 LOTS
OPEN SPACE REQUIRED (650 S.F.) x (41 LOTS)	0.52 ACRES
LOTS < 10,000 S.F. 16 LOTS x 10,000 S.F. = 160,000 S.F./43,560 = 3.67 AC	16 LOTS
TOTAL REDUCED LOT AREA LOTS #4-11, #14-15, #18-19, #21-23	3.21 ACRES
ADD. OPEN SPACE REQUIRED 3.67 AC - 3.21 AC	0.46 AC
TOTAL OPEN SPACE REQUIRED 0.52 AC + 0.46 AC	0.98 AC
TOTAL OPEN SPACE PROVIDED	2.85 AC

SITE DATA CHART	
GROSS ACREAGE	16.51 AC
NET ACREAGE	15.87 AC
EXISTING ZONING	R-100
PROPOSED ZONING	RS-100 PRD
TOTAL UNITS/LOTS	41
GROSS DENSITY	2.48 LOTS/AC
NET DENSITY	2.68 LOTS/AC
MINIMUM LOT SIZE	65' IAT B.S.L.J
MINIMUM LOT WIDTH	8,000 S.F. MIN.
MINIMUM FLOOR AREA	1,800 S.F. MIN.
SETBACKS	
FRONT (EXTERIOR)	35'
FRONT (INTERIOR) *VARIANCE REQUIRED*	15'
REAR	30'
SIDE *VARIANCE REQUIRED*	5'
MAX BUILDING HT.	35'
PARKING REQUIRED (2 SPACES x 41 LOTS)	82 SPACES

LOT CHART			
LOT	AREA S.F.	LOT	AREA S.F.
1	17,096 S.F.	22	9,199 S.F.
2	11,397 S.F.	23	9,825 S.F.
3	10,741 S.F.	24	10,598 S.F.
4	9,588 S.F.	25	11,224 S.F.
5	9,328 S.F.	26	11,850 S.F.
6	9,328 S.F.	27	12,476 S.F.
7	9,328 S.F.	28	13,101 S.F.
8	9,328 S.F.	29	13,727 S.F.
9	9,328 S.F.	30	14,353 S.F.
10	9,328 S.F.	31	12,922 S.F.
11	9,328 S.F.	32	10,131 S.F.
12	10,045 S.F.	33	12,771 S.F.
13	10,045 S.F.	34	12,728 S.F.
14	9,328 S.F.	35	19,787 S.F.
15	9,328 S.F.	36	19,101 S.F.
16	10,045 S.F.	37	16,651 S.F.
17	10,045 S.F.	38	10,014 S.F.
18	9,328 S.F.	39	12,546 S.F.
19	9,328 S.F.	40	9,172 S.F.
20	21,229 S.F.	41	12,271 S.F.
21	8,573 S.F.		
TOTAL: 41	475,856 S.F.		

UTILITIES NOTES	
SEWER	- GWINNETT COUNTY
WATER	- GWINNETT COUNTY

REVISIONS	BY
REVISION DESCRIPTION	BY
REVISION DATE	BY

THIS DRAWING IS THE PROPERTY OF THE ENGINEER AND MAY NOT BE USED OR REPRODUCED WITHOUT HIS WRITTEN PERMISSION



48N12, LLC
P.O. BOX 720314
ATLANTA, GA 30358
404-987-1224

REZONING PLAN
CREEKSIDE SUWANEE DAM
LL 340, 7TH DISTRICT, GWINNETT COUNTY, GEORGIA

DRAWN BY X
CHECKED BY JL
DATE 06-01-22
SCALE 1" = 60'
JOB NO. 22-008
CAD FILE 22008-ZONING.dwg

SHEET
Z-1

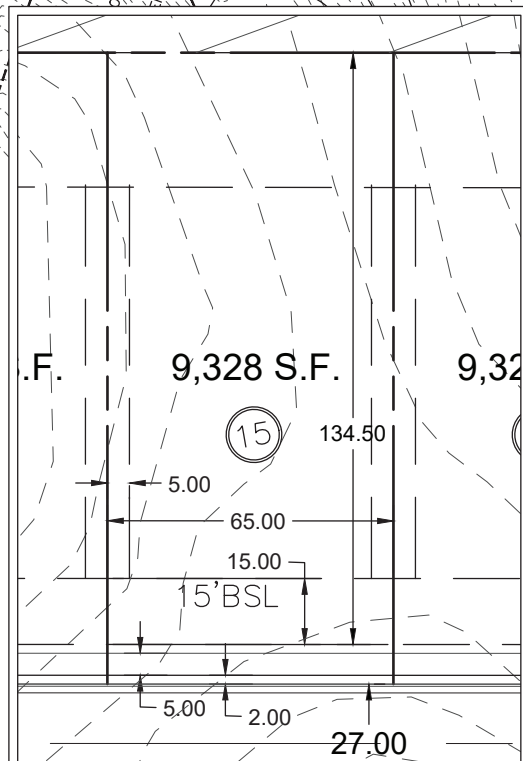
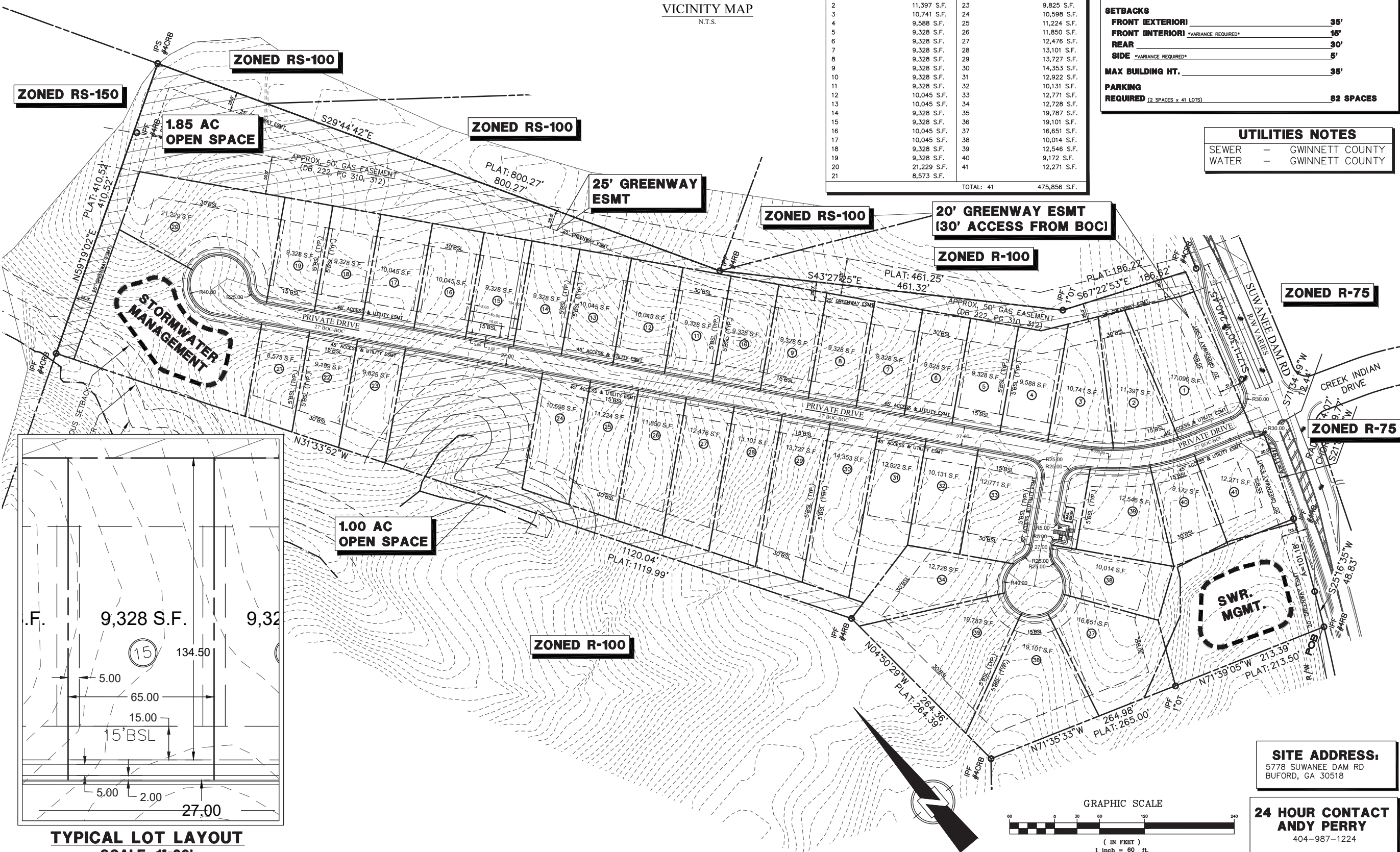

SITE ADDRESS:
5778 SUWANEE DAM RD
BUFORD, GA 30518

24 HOUR CONTACT
ANDY PERRY
404-987-1224

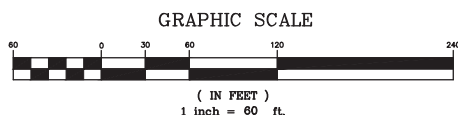

6/25/2022 5:01 PM J:\06\4122.DWG\22008.ZONING.dwg SHELTON